



National Plastic Heater Sensor & Control Inc

**50 Doctor Kay Dr., Unit B-13 Schomberg, Ontario,
L0G 1T0 Canada**

Phone: 905-859-8225 | Fax: 905-859-4691

Toll Free: 1-877-674-9744

sales@npheaters.com

Ceramic Infrared Emitters Technical Manual

Table of Contents

Introduction	2
Agency Approvals	2
Comparing Different Forms of Infrared Heat.....	3
Radiant Emission Patterns of Ceramic Emitters.....	4
Ceramic Infrared Panel Design.....	5
Infrared Heating Basics	6
Infrared Energy	6
Emissivity	6
Electromagnetic Radiation	7
Infrared Spectrum	7
Stefan-Boltzmann Law.....	7
Planck's Law	8
Wien's Law	9
Surface Temperature and Radiation Emissions	10
Emitter Surface Temperature.....	11
Spectral Absorption Curves.....	12
Physical Properties of Materials	13
Reference Data	14
Estimating Power Requirements.....	15
Thermoforming	15
Water Evaporation	18

Introduction

In focus with the Infrared Internationale Mission Statement, we constantly strive to maintain a communication level with our customers. In this revised, second issue of our technical manual, we hope to educate the public on the technical aspects of ceramic infrared emitters. Devised, not as a selling tool but an informational source, there comes a time where selling becomes secondary to informing, and by this process, informing becomes the primary source for selling. It has been proven that what we know and understand best is what we sell and utilize most. It is in this exchange of information that we hope to create a better understanding of our product, the benefits it offers, and heighten awareness to its potential for the future.

Agency Approvals

Salamander ceramic infrared emitters, manufactured by Infrared Internationale of North America, have been tested by Underwriters Laboratories of Northbrook, Illinois, USA. Emitters rated up to 240 volt are UR and C-UR recognized to the standard for safety of electric appliances UL-499 and C-22-2 number 72-M-1984 for electric heating elements.

Reference: Project No. 95NK17113A
File No. E-181581

EC Declaration of Conformity

This is to certify that the:

Salamander Ceramic Infrared Emitters Comprising of:
FTE, FFE, HTE, HFE, HSE, LTE, ESE, and Associated Sheet Metal Fixings and Reflectors

Manufactured By:

Infrared Internationale Engineering
Units 7-11, Granada Park Ind. Estate, Crickhowell,
Powys, Wales, UK, NP8 1HW
Great Britain Tel: (01873) 810999

Infrared Internationale of North America Ltd.
5880 Alpine N.W.
Comstock Park, Michigan 49321
USA Tel: 1-616-784-8997

Is in Compliance With all Implemented EU Requirements:
EU Directive 89/336/EEC Electromagnetic Compatibility
EU Directive 73/23/EEC Low Voltage Safety
EU Directive 93/68/EEC CE Marking

Comparing Different Forms of Infrared Heat

Throughout the years many different forms of infrared heat sources have been developed. Some of the more familiar forms seen today are metal sheathed tubular heaters, quartz tubes, quartz lamps, gas-fired catalytic, flat faced panels, and ceramic emitters. Each source has its own distinctive set of properties:

	Metal Sheath	Quartz Tube	Quartz Lamp	Catalytic	Flat Faced Panels	Ceramic
Radiant Efficiency	56%	61%	86%	80%	88%	96%
Physical Strength	High	Low	Very Low	High	Medium	Medium
Heat-Up Cool Down	Slow	Fast	Very Fast	Very Slow	Slow	Slow
Max. Temp.	1400 ° F	1600 ° F	4000 ° F	800 ° F	1600 ° F	1292 ° F
Color Sensitivity	Low	Low	High	Low	Low	Low

Radiant Efficiency:

The total amount of energy that is emitted from the source as infrared radiation. The balance of heat energy from the sources are transferred via convection and conduction.

Physical Strength:

The physical strength of each source. A high rating indicates a very durable source that can withstand physical abuse such as dropping a wrench on the source.

Heat-Up/Cool Down:

The amount of time required for the source to come up to operating temperature and cool back down to room temperature.

Maximum Temperature:

Maximum operating temperature of the source.

Color Sensitivity:

Refers to the ability of a typical load to absorb the spectral radiation emitted from a source based on the color of the load. The shorter the wavelength emitted from a source the more color sensitive a load will be to the sources spectral radiation.

Radiant Emission Patterns of Ceramic Emitters

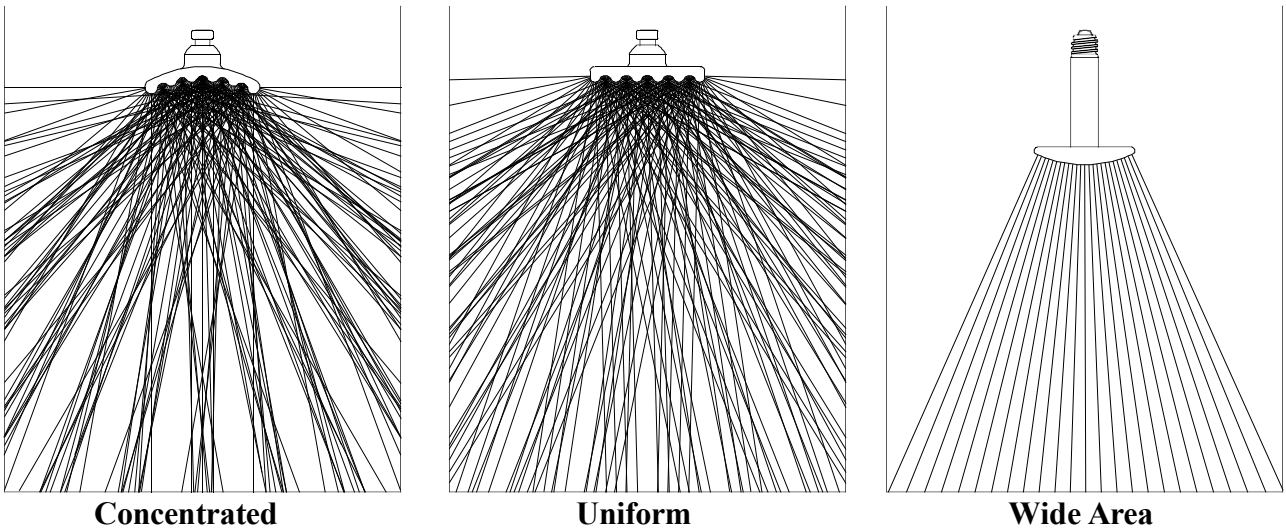

Salamander ceramic emitters are manufactured with three basic emitter faces: concave, flat, and convex. These emitter face styles will result in the specific radiant emission patterns as shown above. Note: Infrared radiation is emitted at right angles to the emission surface.

Concentrated: The concave surface will emit a "concentrated" radiant pattern which is highly effective when zone heating is desired as well as radiant heating in general.

Uniform: The flat surface will produce a "uniform" pattern for even heating at a close proximity between the emitter and the target being heated.

Wide Area: The convex shape gives off a "wide area" pattern which is desirable in comfort heating or other applications that require a dispersed radiant emission pattern.

Salamander Radiant Emission Grid

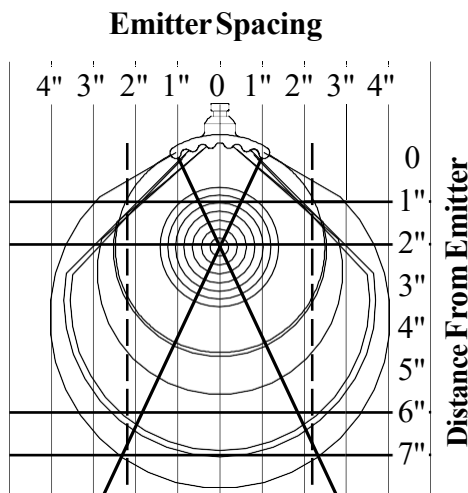

The *Salamander* radiant emission grid can be used to determine the proper ceramic emitter spacing when used in an application such as an infrared panel. In order to achieve an even heat pattern it is critical that the emitters are spaced so that their radiant emission patterns overlap when reaching the target. The more overlap that occurs, the more even the heat will be across the face of the product being heated. The area of highest radiant emission intensity for a single emitter is shown within the two dark crossed lines on the grid. In order for element emissions to overlap, the dashed line shows an intersection point at a distance of 7" will occur if the emitters are placed a distance of 2" apart from edge to edge. This same concept should be used to either determine the distance to place the product if using an existing panel, or placement of emitters if building a panel to guarantee radiant emission overlap.

Ceramic Infrared Panel Design

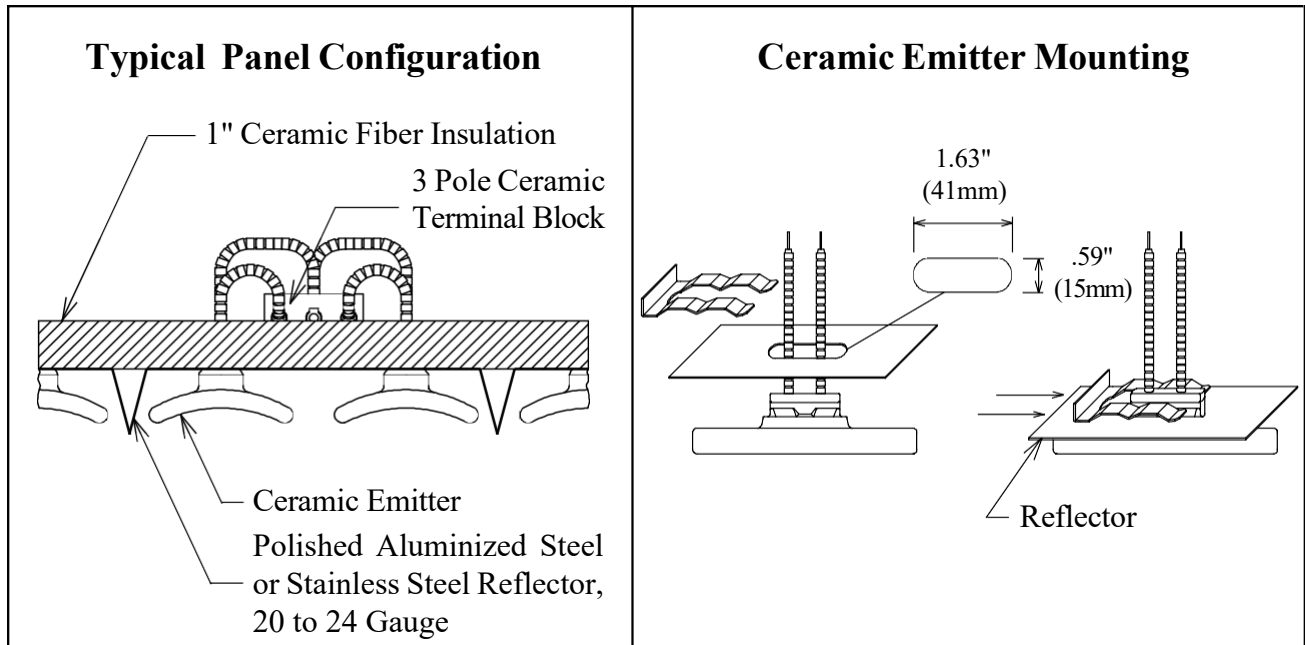

Wiring Specifications:

- * High temperature 842 °F (450°C) MG or similar style wire (with a suitable temperature and amperage rating) should be used for all electrical connections made within the terminal area of the infrared panel. The high temperature wire must be run on top of (or above) the ceramic fiber insulation.
- * Ceramic terminal blocks are recommended to allow for quick emitter replacement, flexibility in zoning, and "touch safe" design.
- * The terminal cover for the infrared panel should be louvered or made out of expanded metal to minimize the temperature within the terminal area.

Emitter Spacing:

The spacing of the emitters should be such that the resulting infrared emissions incident on the target will be even and maximized.

- * Emitters that are tightly spaced in an array will allow the target to be positioned close to the emitters and still result in even heating. The intensity and efficiency of the infrared radiation will be maximized and heat losses will be minimized.
- * Emitters that are loosely spaced in an array will force the target to be positioned further away in order to achieve even heating. This style of panel would typically result in a lower intensity infrared emission.

Infrared Heating Basics

This section of the technical manual is a summary of the physics involved in all infrared heating systems. The information can be used as an aid in calculating system power requirements as well as determining the feasibility of a given infrared heating application.

Infrared Energy:

When infrared energy strikes an object it may be absorbed, transmitted, or reflected from the surface. The sum of the amount of energy absorbed, transmitted, and reflected must equal 100% of the total incident energy. An object is called a "blackbody" if it absorbs (or emits) 100% of incident infrared radiation.

$$1 = \rho + \alpha + \tau$$

Where: ρ = reflectivity
 α = absorptivity
 τ = transmissivity

Example: Infrared energy strikes an object that is 30% reflective, and 20% transparent, how much infrared energy is absorbed by the object?

$$1 = .30 + \alpha + .20$$
$$\alpha = 1 - .30 - .20 = .50 \text{ (or 50\%)}$$

The term "blackbody radiation" was derived from an experiment in cavity radiation. A small hole was drilled into an object and light was focused into the hole. The hole (cavity) appeared to be black. Light that entered the cavity is trapped and absorbed into the object allowing no light to escape. Radiant energy emitted from a "blackbody" source is dependent only on the temperature of the cavity walls and is not at all dependent on any other characteristic of the source such as color.

Emissivity:

A true "blackbody" source for industrial applications has not yet been developed. However, various radiant heating elements are available with a wide range of radiant efficiencies. The efficiency of a radiant heater is given by its emissivity value. Emissivity is defined as the ratio of the radiant energy emitted by an object at a given temperature and the radiant energy emitted by a "blackbody" at the same temperature.

$$e = \frac{W_s}{W_{bb}}$$

Where: e = emissivity of source
 W_s = Total radiant energy emitted from a source at temperature T_1
 W_{bb} = Total radiant energy emitted from a blackbody at temperature T_1

Electromagnetic Radiation:

Infrared radiation is part of a broad electromagnetic spectrum. The relationship between electromagnetic radiation is as follows:

$$\lambda = \frac{c}{f}$$

Where: λ = Wavelength in meters
 c = Speed of light (3×10^8 meters per second)
 f = Frequency in hertz (cycles per second)

Infrared Spectrum:

U.V.	Visible Light V B G Y O R	Near Infrared Deep Penetration For Medical Uses	High Intensity	Far Infrared Low Intensity
	0.4 μ m	0.7 μ m	2.8 μ m	10.0 μ m

Stefan-Boltzmann Law:

The Stefan-Boltzmann Law gives the total power radiated at a specific temperature from an infrared source. That is, the entire amount of infrared radiation (at a specific temperature) emitted from a given source at all associated wavelengths.

$$R = (e) \times (\sigma) \times (T^4) \quad \text{Watts/in}^2$$

Where: σ = Stefan-Boltzmann Constant
[36.58072×10^{-12} W/ in² · °K]
 e = Emissivity Value of the Source
 T = Surface Temperature of the Source
in K (Kelvin.)

Planck's Law:

In order to understand the spectral distribution of infrared radiation from a source we must first understand Planck's Law. Planck's Law gives us the spectral distribution of radiation from a blackbody source. That is, a source that emits 100% infrared radiation at a given single temperature. It is important to understand at this point that in practice, infrared sources are made up of thousands of "point sources" that are all at different temperatures. Each point source will have a different spectral distribution and the combination of point sources will make up the entire spectral distribution. Therefore, we can only approximate the spectral distribution using an average surface temperature and emissivity value.

$$R(\lambda) = \frac{(e) \times (2.416069 \times 10^{-25}) \text{ Watts}}{(\lambda)^5 [\exp^{.014408/\lambda T} - 1]} \text{ in}^2 \cdot \mu\text{m}$$

Where: e = Emissivity of Source
 λ = Wavelength in Meters
 T = Temperature in K (Kelvin)
 $K = (^\circ\text{F} + 460) / 1.8$

**Spectral Distribution of a "Blackbody"
At Various Temperatures**

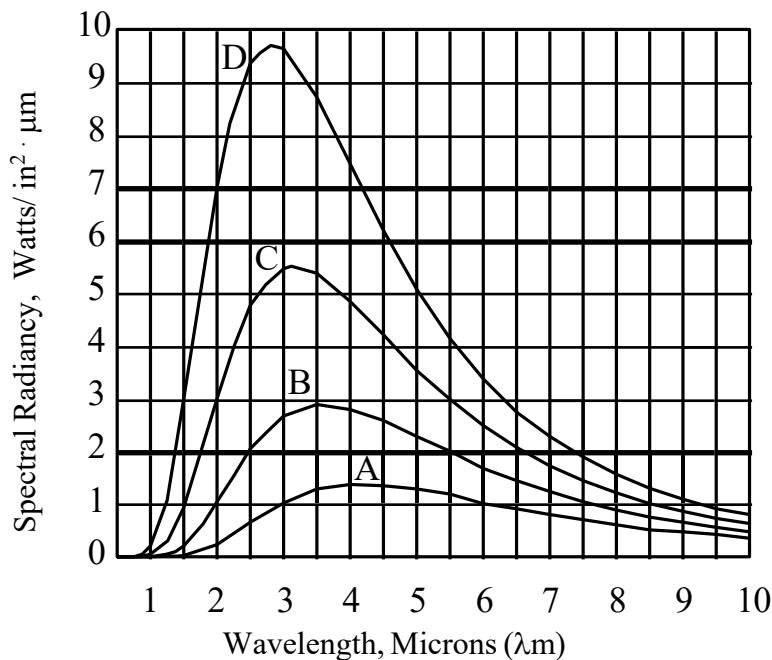

"A"....800 °F, $\lambda_m = 4.14 \mu\text{m}$ "B"....1000 °F, $\lambda_m = 3.57 \mu\text{m}$
 "C"....1200 °F, $\lambda_m = 3.14 \mu\text{m}$ "D"....1400 °F, $\lambda_m = 2.81 \mu\text{m}$

Notice in the Planck's Law curves shown on the previous page that the spectral radiancy of the source increases proportionally with the source temperature. In other words, the radiant infrared output from a source increases as the temperature of the source increases. The overall infrared emissions from a given source is equal to the area under the associated Planck's Law curve. By integrating Planck's Law at a given temperature with respect to the wavelength we can calculate the amount of infrared emissions within a given range of wavelengths (See graph below).

Also notice that as the temperature of the source increases, the peak wavelength of the source becomes shorter. When the temperature of the source becomes too high a noticeable amount of energy is emitted from the source as light. That is, a portion of the energy emitted from the source falls within the wavelengths associated with light. Referring back to the infrared spectrum chart shown on page 7, visible light occurs starting at .40μm and ends at .70μm. The infrared spectrum starts at .70μm and extends to 1000μm. Although the useful range of wavelengths for infrared heating applications occurs between .70μm to 10μm.

**% Of Infrared Radiation Emitted From A Blackbody
Between 3 and 10 μm**

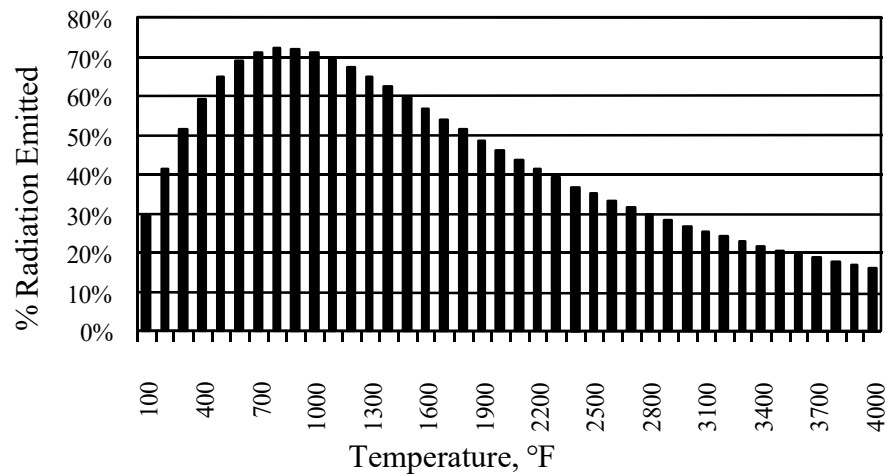

Wien's Law:

Wien's Law gives the wavelength at which the spectral distribution (given by Planck's Law) of the radiation emitted by a blackbody is at a maximum point. Note, however, that according to Planck's Law a range of wavelengths is emitted from a source at a specific temperature! Wien's Law simply gives the "peak wavelength".

$$\lambda_m = \frac{2.898 \times 10^{-3} \text{ m K}}{T_k}$$

Where: λ_m = Peak Wavelength in Meters
 T_k = Temperature in K (Kelvin)
 $K = (°F + 460)/1.8$

Surface Temperature and Radiation Emissions:

The curve shown below can be used as a quick reference to estimate the amount of infrared radiant energy emitted from a given source. The curves were derived using the Stefan-Boltzmann Law. For example, a 1000 °F (538°C or 811 K) infrared source with an emissivity value of .80 (80%) will have an approximate radiant emission (from the curves below) of 12.5 Watt / in². Using the Stefan-Boltzmann equation yields the following:

$$R = (.80)(36.58072 \times 10^{-12})[(811)^4] = 12.65 \text{ Watts / in}^2$$

**Surface Temperature vs. Radiation Emission
at Various Emissivity Values**

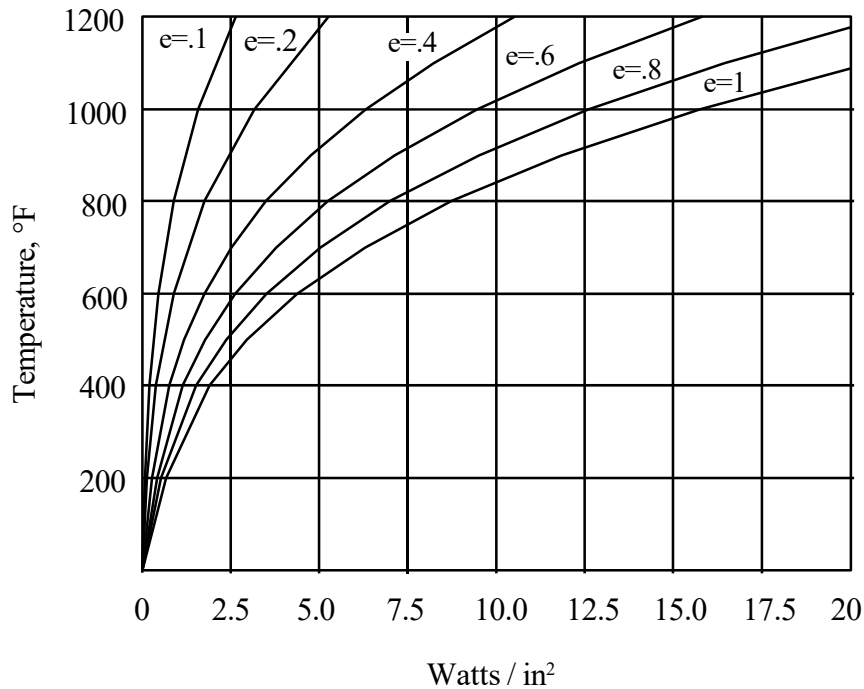

Emitter Surface Temperature

The warm-up and cool-down curves shown below are based on the Salamander FTE style ceramic emitter. The curves for the Salamander HTE and LTE emitter can be approximated by using the following factors. If it is desired to know the time/temperature relationship for an HTE emitter, multiply the wattage of the desired HTE emitter by a factor of 2. That is, an HTE-500 will have the same temperature characteristics as an FTE-1000. If it is desired to know the time/temperature curves for an LTE emitter, multiply the wattage of the desired LTE emitter by a factor of .55. That is, an LTE-900 will have the same temperature characteristics as an FTE-500 (approximately). Note that the time/temperature curves are based on a **single FTE emitter** in a 70 °F (21 °C) ambient environment. When using the ceramic emitters in an array of multiple units the time/temperature curves can be significantly different.

**Surface Temperature Warm-Up Time:
Single Emitter in 70 °F (21 °C) Ambient**

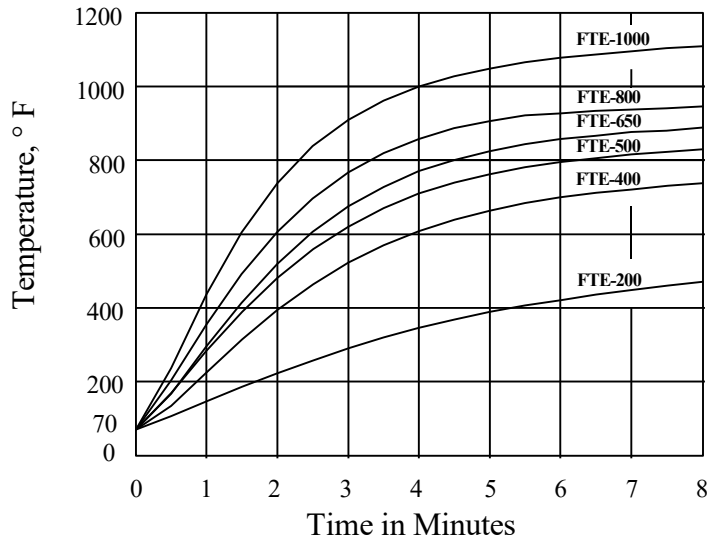

**Surface Temperature Cool-Down Time:
Single Emitter in 70 °F (21 °C) Ambient**

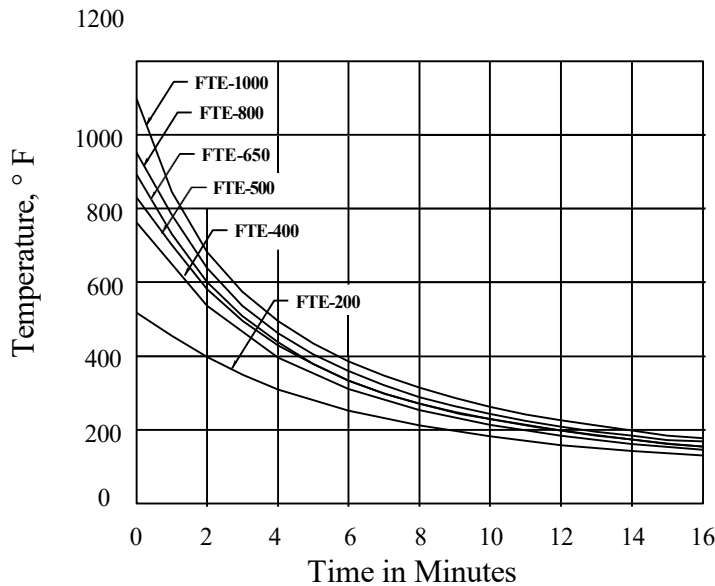

Spectral Absorption Curves

Spectral Absorption Curves:

The following spectral absorption curves show the range of wavelengths that a particular material will absorb infrared radiation as well as the percentage of absorption. These curves are only representative of a particular sample of a given "virgin" material. In actual practice, coloring agents and other additives will change the look of the curves. However, the curves can be used to get a general idea of the range of infrared radiation in which the material will absorb.

Spectral Absorption Curve For Water

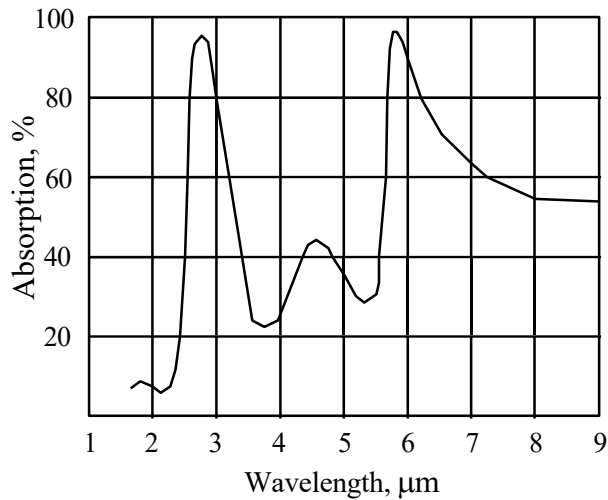

Spectral Absorption Curve For PVC

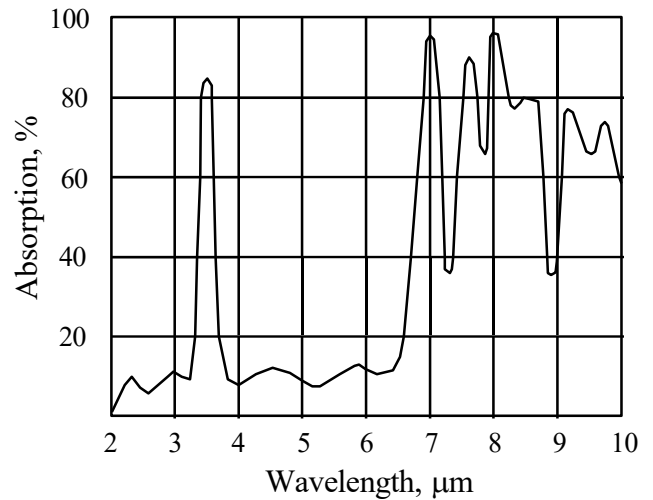

Spectral Absorption Curve For Polystyrene

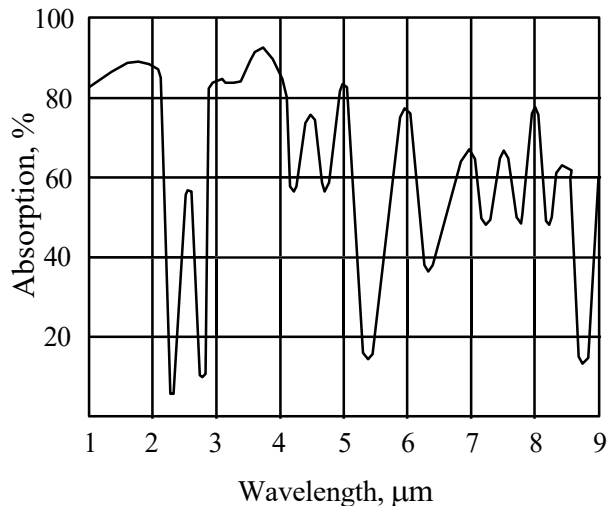

Spectral Absorption Curve For Polyethylene

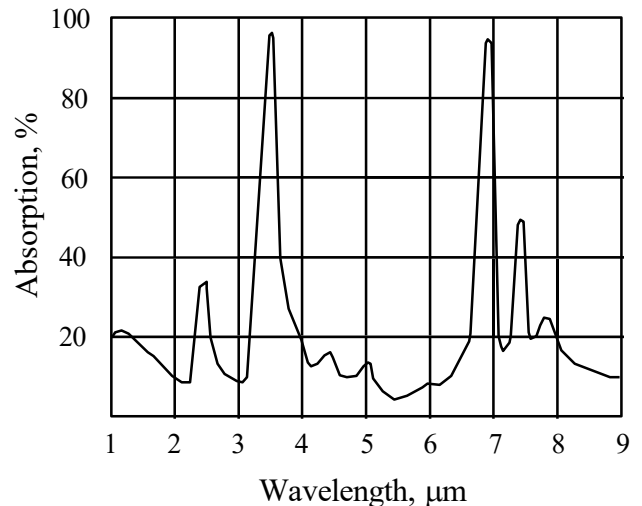

Physical Properties Of Materials

Material	Density lb/ft ³	Specific Heat Btu lb·ft ²	Emissivity	Thermal Conductivity	Latent Heat of Fusion	Latent Heat of Evaporation	Melting Point	Boiling Point
				Btu · in hr · ft ² · °F	Btu/lb	Btu/lb	°F	°F
Non-Metallic Solids:								
Asphalt	65	0.40	0.93	1.20	40		250	
Beeswax	60			1.67	75		144	
Carbon	138	0.20		165				
Cotton	92	0.31	0.77	0.41				
Glass	165	0.20		5.4				
Ice	57	0.53					32	
Paper	58	0.45	0.93	0.82				
Paraffin	56	0.70		1.56	63		133	
Rubber	76	0.44	0.90	1.10				
Wood, Oak	50	0.57	0.90	1.15				
Wood, Pine	34	0.67	0.90	0.90				
Plastics:								
ABS	69-76	0.3-0.4						
Acrylic	69-74	0.34						
Epoxy	66-88	0.25-0.3						
Flouroplastic	131-150	0.28						
Nylon	67-72	0.3-0.5	Most					
Phenolic	85-124	0.35	Non-Metals					
Polycarbonate	74-78	0.30	Have An					
Polyester	66-92	0.2-0.35	Emissivity					
Polyethylene	57-60	0.54	of 0.90					
Polyimides	90	0.27-0.3						
Polypropylene	55-57	0.46						
Polystyrene	66	0.32						
PVC	72-99	0.2-0.3						
Metals:								
Aluminum	169	0.24		1536			1190	
- Polished			0.09					
- Med. Oxide			0.19					
- Heavy Oxide			0.31					
430 Stainless	475	0.11		150			2650	
- Polished			0.17					
- Med. Oxide			0.57					
- Heavy Oxide		0.85						
Liquids:								
Oil, Cottonseed	60	0.47	0.90					
Oil, Vegetable	57.5	0.43	0.90					318
Paraffin	47.1	0.71						750
Water	62.4	1.0	0.93	4.08		965		212

Reference Data

Temperature:

$$\begin{aligned} ^\circ\text{C} &= 5/9(^{\circ}\text{F} - 32) & \text{Or} & \quad ^\circ\text{F} = 9/5(^{\circ}\text{C}) + 32 \\ \text{K} &= (^{\circ}\text{F} + 460)/1.8 & \text{Or} & \quad \text{K} = ^\circ\text{C} + 273 \\ ^\circ\text{R} &= ^\circ\text{F} + 460 \end{aligned}$$

Electrical:

Ohms Law: E = Volts
 I = Amps
 R = Ohms
 W = Watts

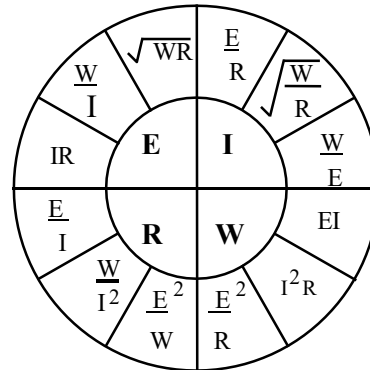

3 Phase Wye (Balanced Load)

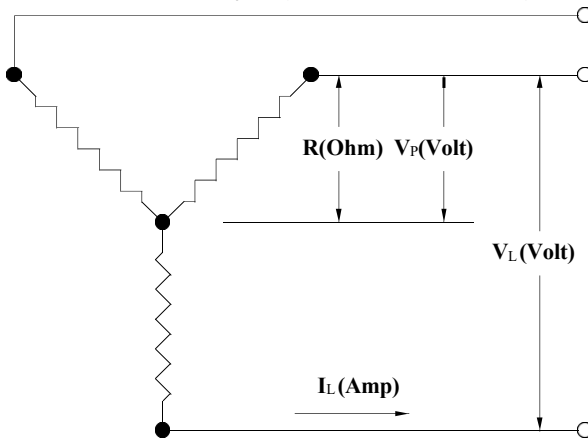

$$\begin{aligned} W(\text{Total Watt}) &= \sqrt{3} V_L \times I_L \\ V_P &= V_L / \sqrt{3} \\ R &= V_P / I_L \end{aligned}$$

3 Phase Delta (Balanced Load)

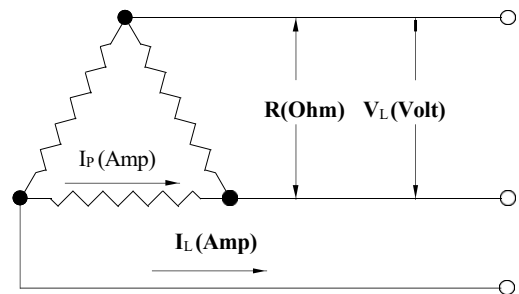

$$\begin{aligned} W(\text{Total Watt}) &= \sqrt{3} V_L \times I_L \\ I_P &= V_L / R \end{aligned}$$

Conversion Factors:

1 KW = 1000 Watt	1mm = .03937 Inch	1kg = 2.205 lb
3412 BTU = 1 KW-HR	1m = 39.37 Inch	1g = .002205 lb
1 HP = .746 KW	1 Inch = 2.54cm	1 U.S. Gal. = .1337 Cu. Ft.
1 Boiler H.P. = 9.8 KW	1km = .6214 Mile	1 U.S. Gal. = 3.785 liters

Estimating Power Requirements

In a given heating system any or all of the three modes of heat transfer (convection, conduction, radiation) can be utilized. The intended purpose of the following examples is to focus on the infrared heating component only of each heating system. That is, it is assumed that 100% of the heat transfer in each example is by infrared radiation and any heat losses are considered to be negligible.

Thermoforming:

Given: A thermoforming application requires that an 1/8" thick PVC sheet be heated to 350 °F (177 °C) in 1 minute. Determine the power required using only infrared radiation.

Calculations: Emissivity of the infrared source	= .90
Emissivity of PVC Sheet	= .90
Specific Heat of PVC	= .30 BTU / lb. / °F
Density of PVC	= 99 lbs. / ft ³
Temperature Required	= 350 °F (177 °C)
Ambient Temperature	= 65 °F (18 °C)

Convert the PVC target into (lbs. / in²):

$$\text{lbs/in}^2 = (99 \text{ lbs/ft}^3)(1/1728 \text{ in}^3)(.125 \text{ in}) = .007161 \text{ lbs./in}^2$$

The power required to heat the PVC sheet is given by:

$$\frac{\text{Watt-Hour}}{\text{in}^2} = \frac{(\text{Weight})(\text{Specific Heat})(T_1 - T_2)}{3.412}$$
$$= \frac{(.007161)(.30)(350-65)}{3.412} = .179$$

Thermoforming Example (cont.):

Warm-up Time:

$$\text{Warm-up Time} = \frac{\text{Watt-Hour / in}^2}{\text{Watt / in}^2} \times 60 \quad \text{Minutes}$$
$$1 \text{ min.} = \frac{.179}{\text{Watt / in}^2} \times 60$$

Solve the "time" equation for Watt / in²:

$$\text{Watt / in}^2 = \frac{(.179)(60)}{1 \text{ min}} = 10.74$$

$$\text{Watt / in}^2 = 10.74$$

This is the amount of infrared radiant energy that must be absorbed into the PVC sheet to heat the sheet to 350 °F (177 °C) in 1 minute.

At this point one can use Planck's Law and the spectral absorption curve for PVC by superimposing these curves on each other and calculating the total area under the curves at which the two curves intersect (provided that accurate curves are available). This can be extremely time consuming.

A simplified method of estimating the power radiated and absorbed into the PVC sheet is given by the following:

The effective emissivity between two parallel plates is given by:

$$e = \frac{1}{(1/e_1 + 1/e_2 - 1)} = \frac{1}{(1/.9 + 1/.9 - 1)}$$
$$= .82$$

Thermoforming Example (cont.):

Two infrared heater panels will be used. One panel will heat the top of the PVC sheet, the other will heat the bottom of the PVC sheet. Heating both the top and bottom of the PVC sheet will minimize the temperature gradient within the sheet which could cause "part" deformation. Since two infrared panels will be used, the power required per panel is 1/2 of the 10.74 Watts / in². Therefore, 5.37 Watts / in² is required from each infrared panel.

Stefan-Boltzmann Law:

$$R = (.82)(36.58072 \times 10^{-12})((T_1)^4 - (T_2)^4) = 5.37$$

Where T_1 = Source Temperature

$$T_2 = \text{Average PVC Temperature} = (65+350)/2 = 208 \text{ }^\circ\text{F} \\ = 371 \text{ K}$$

Solve the equation for the source temperature.

$$T_1 = \sqrt[4]{\frac{5.37}{(.82)(36.58072 \times 10^{-12})} + (371)^4} \text{ K} \\ = 667 \text{ K} \quad (741 \text{ }^\circ\text{F or } 394 \text{ }^\circ\text{C})$$

Results:

The surface temperature of the source must be at least 741°F (394 °C) to achieve a 350 °F (177 °C) PVC sheet temperature within 1 minute.

Water Evaporation:

Given: Estimate the amount of infrared radiation required to evaporate 4 grams of water per square foot every 5 seconds from a substrate material in a waterbased adhesive application. Assume the substrate to have a negligible mass.

Calculations: Emissivity of the infrared source	= .90
Emissivity of Water	= .93
Specific Heat of Water	= 1.0 BTU / lb. / °F
Latent Heat of Vaporization	= 965 Btu / lb.
Boiling Point of Water	= 212 °F (100 °C)
Ambient Temperature	= 65 °F (18 °C)

Convert the grams of water per square foot to lbs. of water per square inch:

$$(4 \text{ g/ft}^2)(.0022046 \text{ lb/g})(1/144 \text{ ft}^2/\text{in}^2) = 61.24 \times 10^{-6} \text{ lbs/in}^2$$

The power required to heat the water is given by:

$$\frac{\text{Watt-Hour}}{\text{in}^2} = \frac{(\text{Weight})(\text{Specific Heat})(T_1 - T_2)}{3.412}$$

$$= \frac{(61.24 \times 10^{-6})(1.0)(212 - 65)}{3.412} = 2.64 \times 10^{-3}$$

$$\text{Latent Heat of Vaporization} = \frac{(965 \text{ Btu/lb})(61.24 \times 10^{-6} \text{ lbs/in}^2)}{3.412}$$

$$= 17.32 \times 10^{-3}$$

$$\text{Total Power Required} = (2.64 \times 10^{-3}) + (17.32 \times 10^{-3})$$

$$= 22.60 \times 10^{-3} \frac{\text{Watt - Hr}}{\text{in}^2}$$

Water Evaporation Example (cont):

Warm-up Time:

$$\text{Warm-up Time} = \frac{\text{Watt-Hour / in}^2}{\text{Watt / in}^2} \times 60 \quad \text{Minutes}$$

$$5/60 \text{ min.} = \frac{22.6 \times 10^{-3}}{\text{Watt / in}^2} \times 60$$

Solve the "time" equation for Watt / in²:

$$\text{Watt / in}^2 = \frac{(22.6 \times 10^{-3})(60)}{5/60 \text{ min}} = 16.27$$

The effective emissivity between two parallel plates is given by:

$$e = \frac{1}{(1/e_1 + 1/e_2 - 1)} = \frac{1}{(1/.9 + 1/.93 - 1)}$$
$$= .84$$

Stefan-Boltzmann Law:

$$R = (.84)(36.58072 \times 10^{-12})((T_1)^4 - (T_2)^4) = 16.27$$

Where T_1 = Source Temperature

$$T_2 = \text{Average Water Temperature} = (65+212)/2 = 138.5 \text{ }^\circ\text{F} (59 \text{ }^\circ\text{C})$$
$$= 332.5 \text{ K}$$

Solve the equation for the source temperature.

$$T_1 = \sqrt[4]{\frac{16.27}{(.84)(36.58072 \times 10^{-12})} + (332.5)^4} \quad \text{K}$$

$$= 858 \text{ K} = 1084 \text{ }^\circ\text{F} (584 \text{ }^\circ\text{C})$$

Results: The surface temperature of the source must be at least 1084°F (584 °C) to evaporate 4 grams of water within 5 seconds.



National Plastic Heater, Sensor and Control Inc.
Beespoke Top Industrial Process Heaters
Product Catalogues



[Custom Industrial Process Heaters](#)



[High Temp. Euro Plugs & Heater Accessories](#)

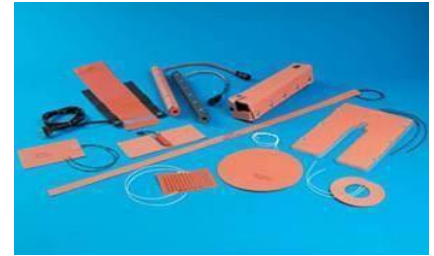

[Silicone Rubber Heaters](#)



[Custom Kapton \(Polyimide\) Heaters](#)



[Best Over-The-Side Teflon \(PTFE\) Heaters](#)



[Hot Runner Coil Heaters](#)



[Custom Pressed In Brass Coil Heaters](#)



[Hot Tip Mini Split Sheath Cartridge Heaters](#)



[Standard Cartridge Heaters](#)



[Vacuum Freeze Dry Equipment with Silicone Rubber Heaters](#)

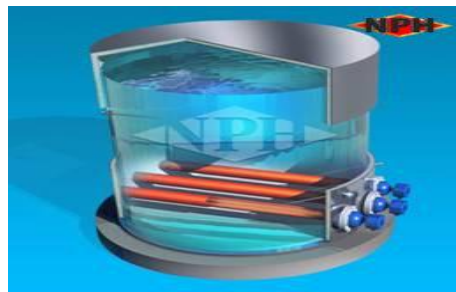

[Pipe Insert Heaters](#)



[Ceramic Infrared Emitters- Heaters](#)